

## BRUNNER WATER BOILERS



### HKD 2.2 XL-SK/s

State: 2018-05-22



**BRUNNER**<sup>®</sup>  
*made in germany.*

# Dimension sheets - HKD 2.2 XL-SK/s

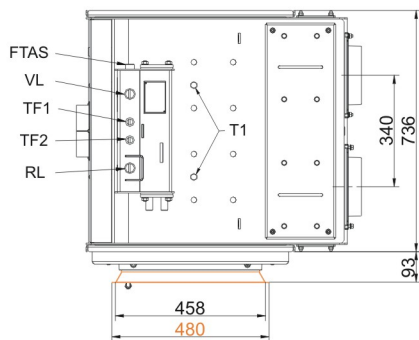
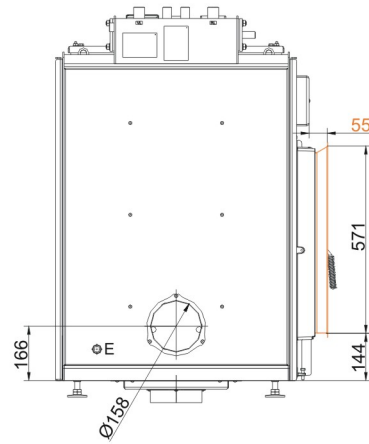
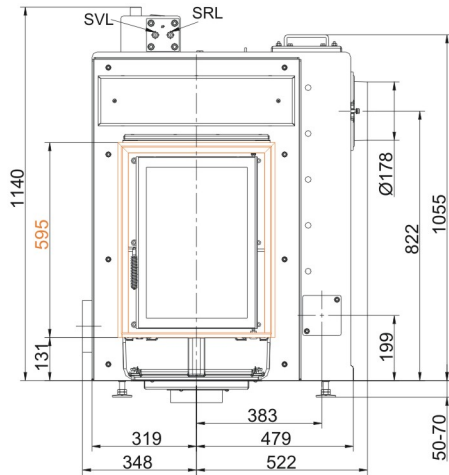

- VL supply 1"ext. th.
- RL return boiler 1"ext.th.
- E drain 1/2"int. th.
- SVL supply cooling pipe outlet ext.th.
- SRL return cooling pipe outlet 1/2"ext.th.
- FTAS socket for thermal safety sensor int.th.
- TF1 socket 1/2" for sensor int.th.
- TF2 socket 1/2" for sensor int.th.

... with door frame

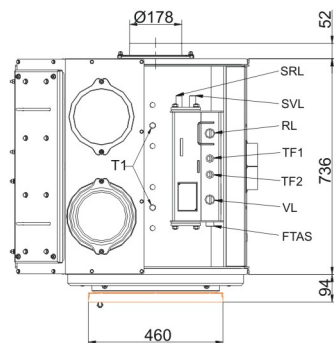
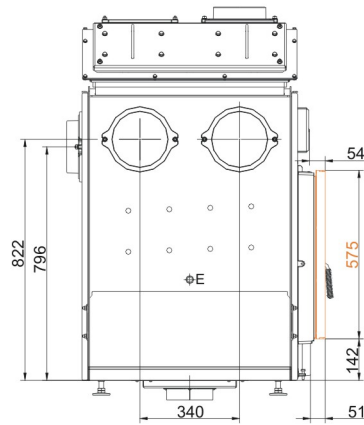
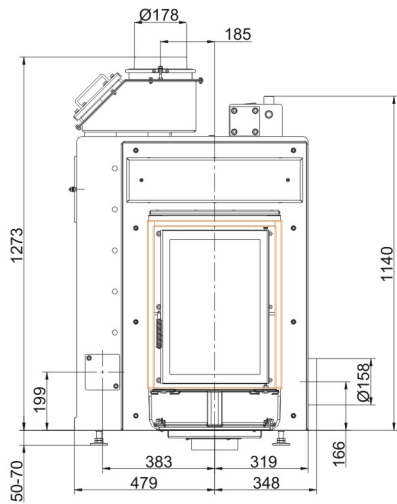

- VL supply 1"ext. th.
- RL return boiler 1"ext.th.
- E drain 1/2"int. th.
- SVL supply cooling pipe outlet ext.th.
- SRL return cooling pipe outlet 1/2"ext.th.
- FTAS socket for thermal safety sensor int.th.
- TF1 socket 1/2" for sensor int.th.
- TF2 socket 1/2" for sensor int.th.

... with flue gas adapter and mounting frame

# Dimension sheets - HKD 2.2 XL-SK/s

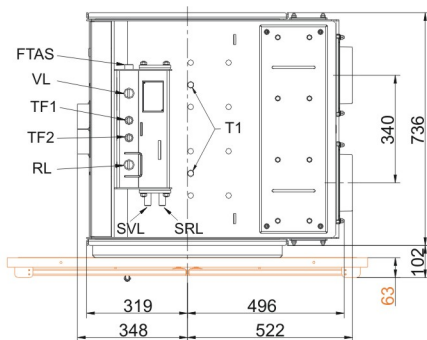
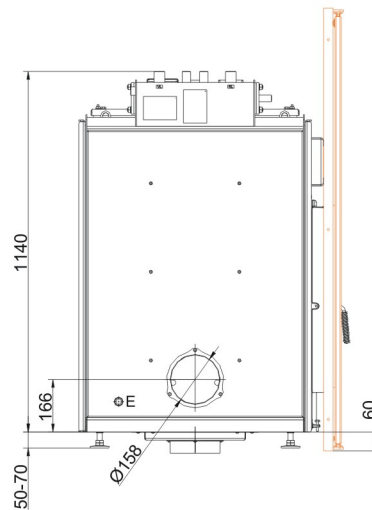
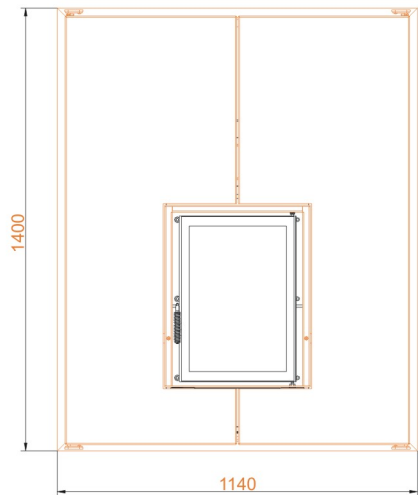

- VL supply 1"ext. th.
- RL return boiler 1"ext.th.
- E drain 1/2"int. th.
- SVL supply cooling pipe outlet ext.th.
- SRL return cooling pipe outlet 1/2"ext.th.
- FTAS socket for thermal safety sensor int.th.
- TF1 socket 1/2" for sensor int.th.
- TF2 socket 1/2" for sensor int.th.

... with front door

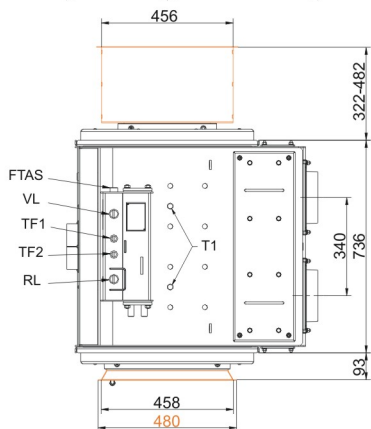
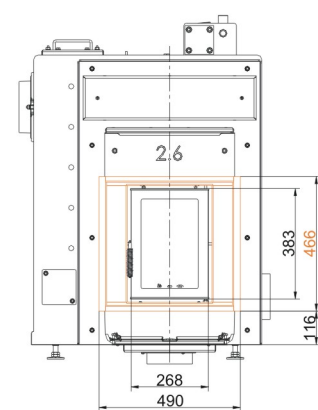
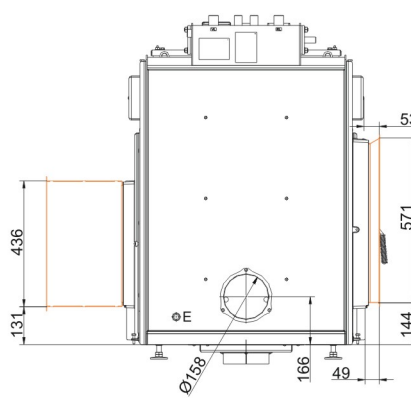
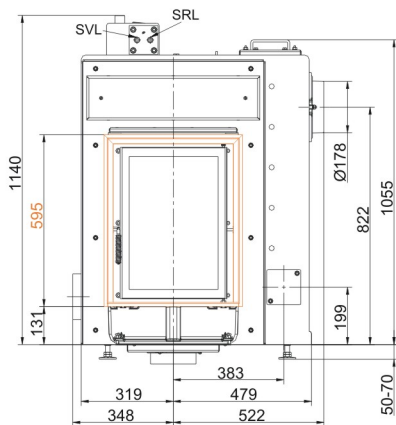

- VL supply 1"ext. th.
- RL return boiler 1"ext.th.
- E drain 1/2"int. th.
- SVL supply cooling pipe outlet ext.th.
- SRL return cooling pipe outlet 1/2"ext.th.
- FTAS socket for thermal safety sensor int.th.
- TF1 socket 1/2" for sensor int.th.
- TF2 socket 1/2" for sensor int.th.

... with additional fire door and door frame

# Dimension sheets - HKD 2.2 XL-SK/s

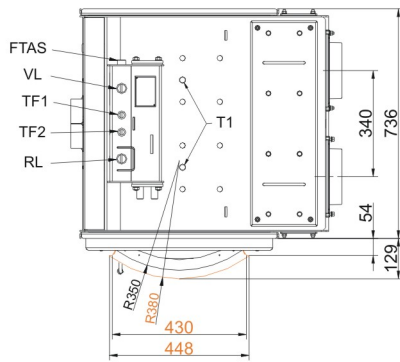
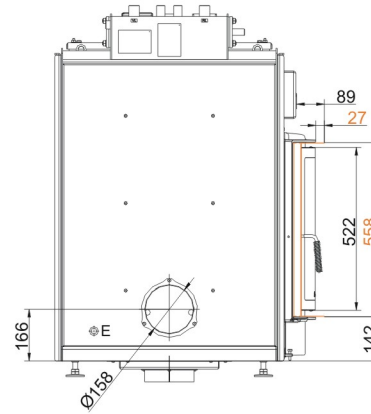
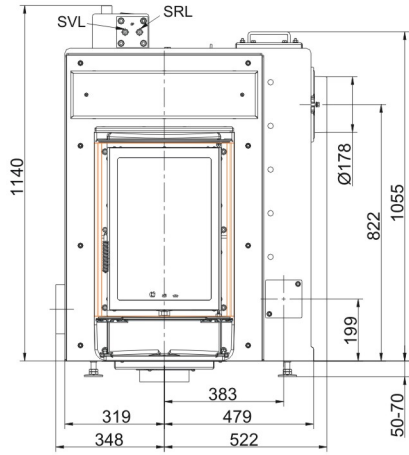

- VL supply 1" ext. th.
- RL return boiler 1" ext. th.
- E drain 1/2" int. th.
- SVL supply cooling pipe outlet ext. th.
- SRL return cooling pipe outlet 1/2" ext. th.
- FTAS socket for thermal safety sensor int. th.
- TF1 socket 1/2" for sensor int. th.
- TF2 socket 1/2" for sensor int. th.

... round with door frame

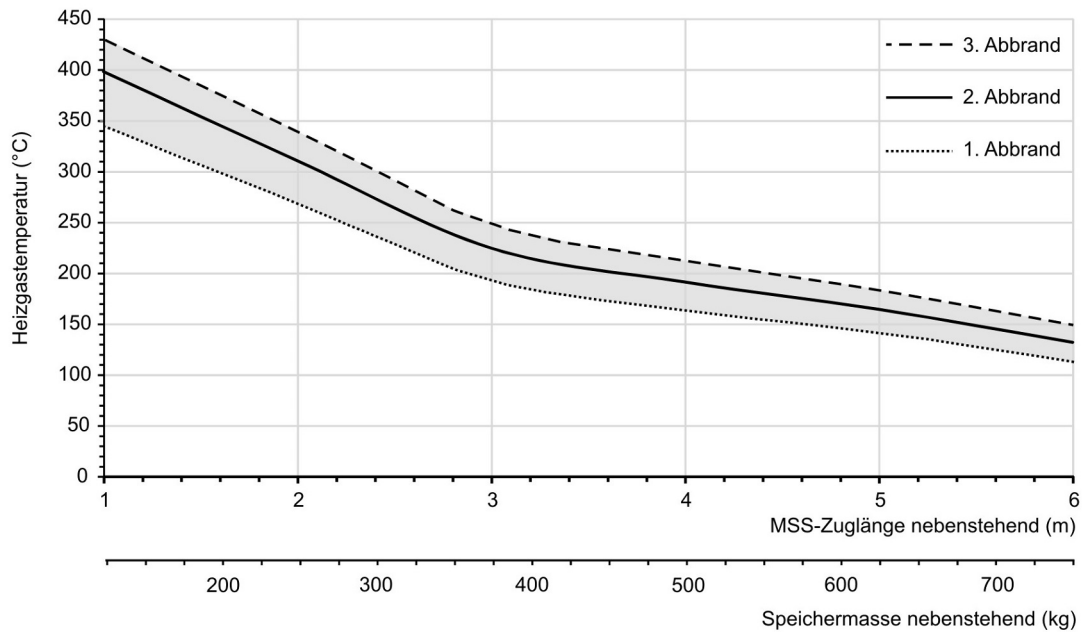

... Auslegungsdigramm für nebenstehende Speichermasse

We suggest for CAD planing Palette CAD. Permanent updated drawings: [www.brunner.de](http://www.brunner.de)  
 Frames / front versions are marked colored.

## Planning and installation - HKD 2.2 XL-SK/s

Tested according to		EN 13229 W	EN 13229 W
Values measured at		Rated capacity	practical avg.
EEl		120.2	120.2
<b>Data for functional demonstration</b>			
Rated heat power	kW	13	-
Fire wood volume	kg/h	3.5	8.8
Combustion performance	kW	15	33
Flue gas mass flow	g/s	10	29
Outlet temperature (before heating surface)	°C	480	550
Flue gas temperature after:			
1 x adjoining cast iron radiator (GNF 8/10)	°C	135	180
4,9 m ceramic accumulator <sup>1)</sup>	°C	-	180
3,4 m accumulation stones (MSS) <sup>1)</sup>	°C	-	210
boiler	°C	115	180
Necessary supply pressure	Pa	15	15
Combustion air consumption	m <sup>3</sup> /h	30	80
Combustion air connection Ø	mm	160	160
<b>Heat distribution</b>			
Insert / heat accumulator	%	10 / 5 - 45	10 / 5 - 45
Glass pane (single / double)	%	30 / 25	30 / 25
Boiler	%	25 - 60	25 - 60
<b>Cross-section of gratings <sup>2)</sup></b>			
Convection air	cm <sup>2</sup>	500 / 200 / 300	500 / 200 / 300
Supply air	cm <sup>2</sup>	500 / 200 / 300	500 / 200 / 300
<b>Minimal distances of the fireplace</b>			
to insulation layer	cm	6	6
to mounting floor	cm	6	6
<b>Thermal insulation without / with air gratings <sup>3)</sup></b>			
Mounting wall	cm	8 / 6	8 / 6
Floor	cm	0 / 0	0 / 0
Ceiling	cm	13 / 10	13 / 10
Brick lining for combustible wall	cm	10	10
<b>Water boiler data</b>			
Max. operating pressure	bar	3	3
Max. flow temperature	°C	100	100
Water volume	liter	88	88
Connections flow / return	inches	1	1
<b>Weight</b>			
Fireplace / combustion chamber	kg	423 / 93	
<b>Meets requirement/limit values for:</b>			
Germany/ Austria / Suisse / Norway		1.BImSchV (Stufe 2) / 15a BVG (2015) / LRV / -	

1) Approximate value. Determination according to design characteristics for adjacent storage mass or proof of function provided by calculation

2) for fireplace inserts / flue gas pipe / metallic reheating surface

3) Values determined with upper air sections; stove cladding is heat emitting.